



# ESCALIERS- PASSERELLES

**HAKI France**  
3 allée du Lazio  
Parc Technoland, Bât. C  
69800 Saint-Priest

# Sommaire

3	Informations générales	
4	Présentation	(Code : N221-018)
5	Escalier 3 marches – Passerelle 0,80 m	(Code : N221-019)
6	Escalier 6 marches – Passerelle 1,60 m	(Code : N221-020)
7	Escalier 9 marches – Passerelle 2,40 m	(Code : N221-008)
8	Escalier 12 marches – Passerelle 3,20 m	
9	Plage d'utilisation	
10	Maintenance préventive	

# Informations générales

La mise en place de l'escalier doit impérativement se faire en sécurité.



Prendre les dimensions X et Y pour définir le modèle d'escalier à utiliser, selon la page d'utilisation page 10.

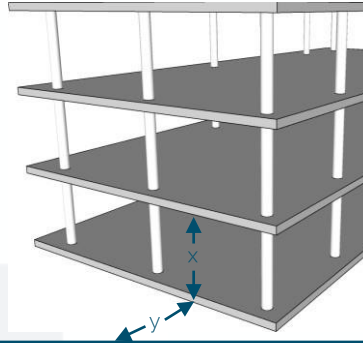

Identifier les supports pour déterminer les types de chevilles et d'ancrages.

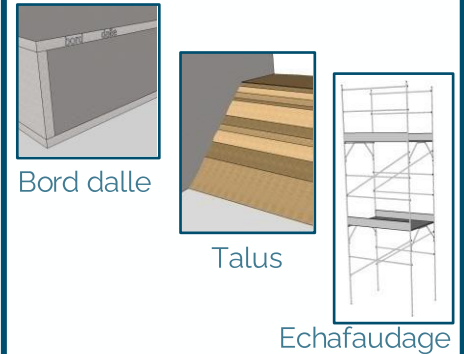

Charge ponctuelle

Max. 150 kg



Charge répartie

100 kg/m<sup>2</sup>

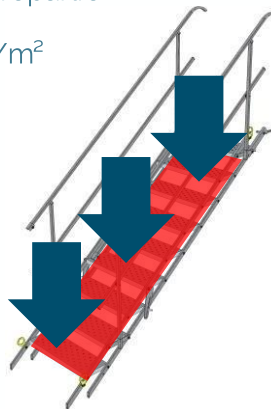

Enlever la saleté et la neige avant installation.



Contrôler l'escalier avant installation.



Min. 30° - max. 55°

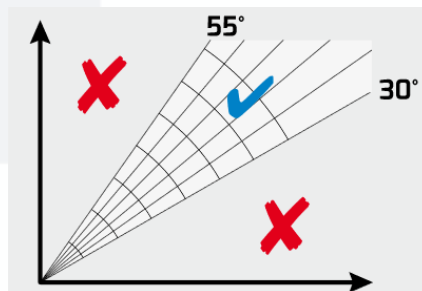

Charge ponctuelle : max. 150 kg

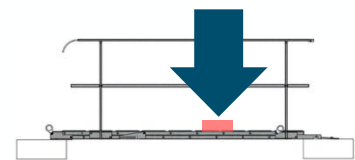

Charge répartie : ≤ 100 kg/m<sup>2</sup>

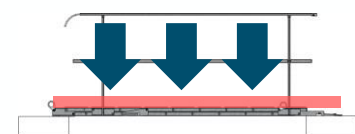

Selon la norme EN 12811-1:2003

# Présentation

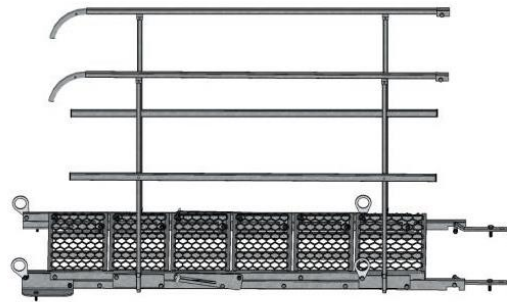
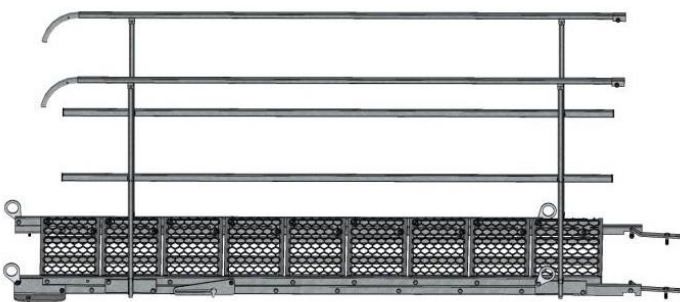
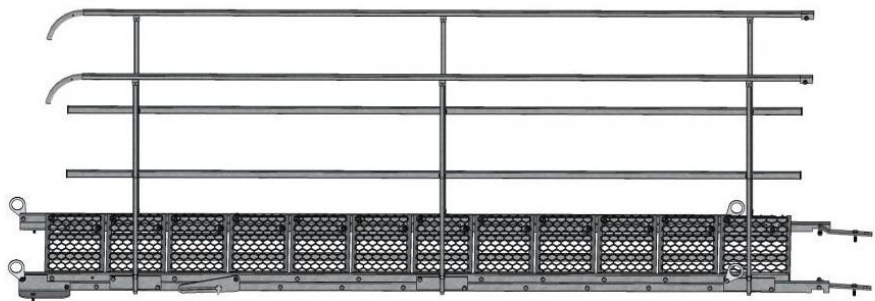
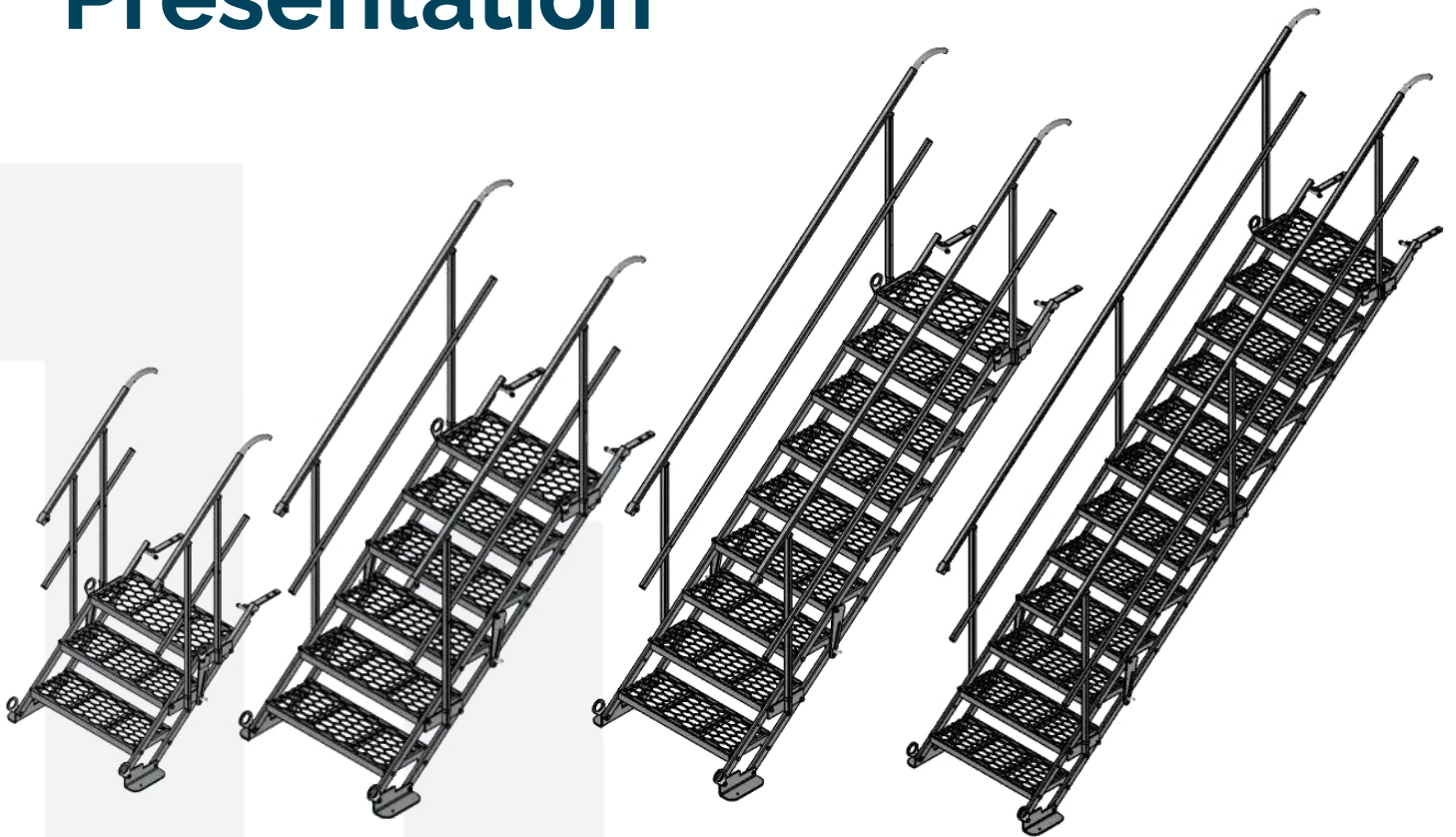

# Escalier 3 marches Passerelle 0,80 m

Code : N221-018

40 kg

EN 12811-1:2003

Charge ponctuelle max. : 150 kg  
Charge répartie max. : 100 kg/m<sup>2</sup>

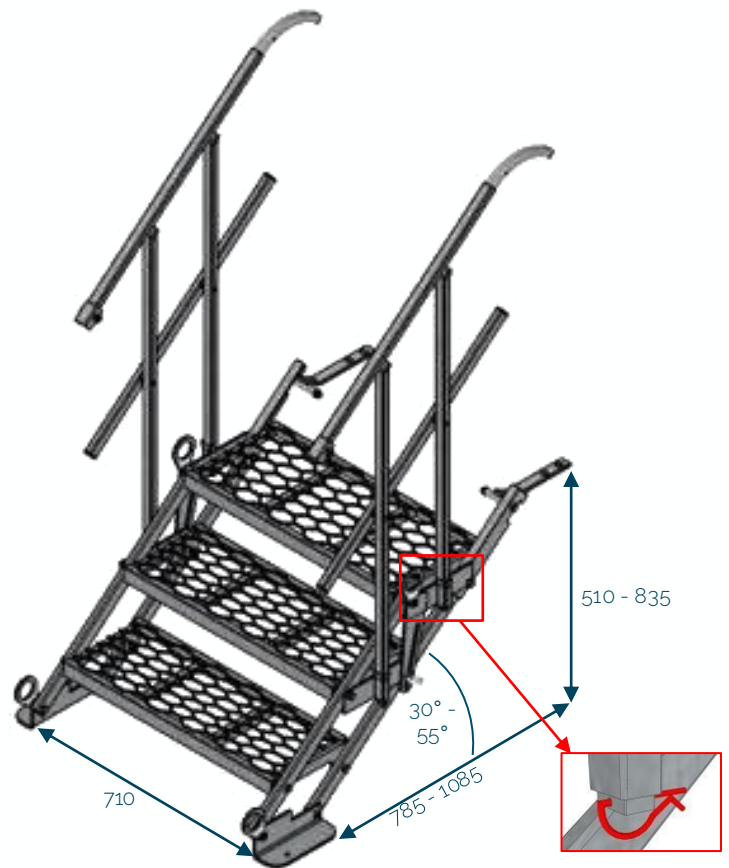
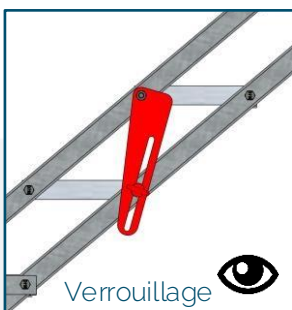
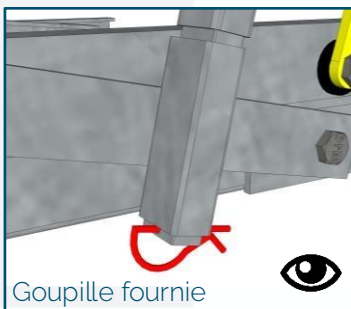
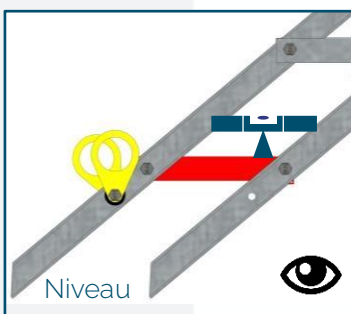

[mm]

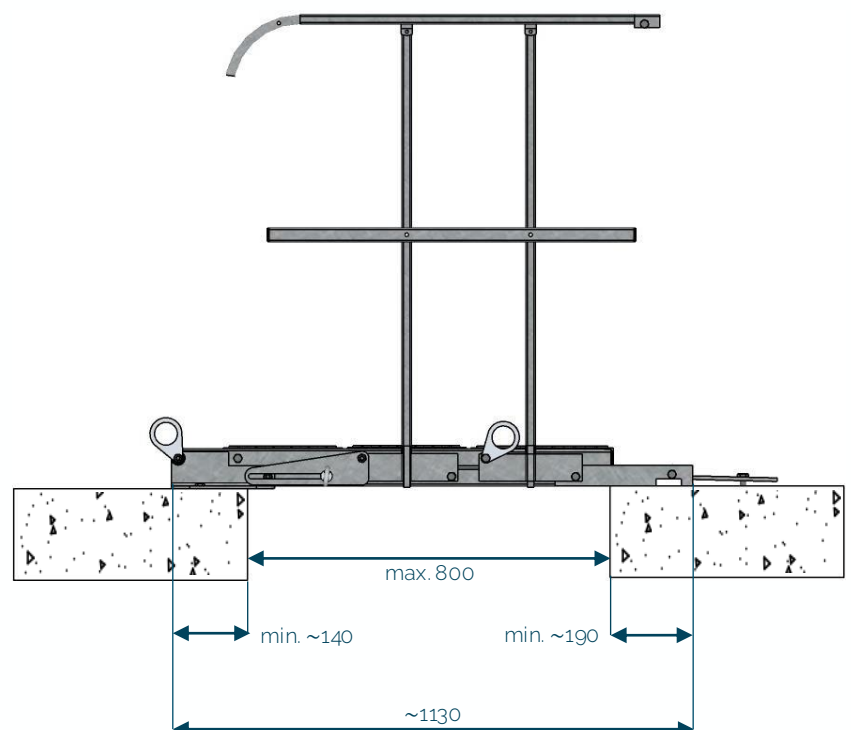

# Escalier 6 marches Passerelle 1,60 m

Code : N221-019

63 kg

EN 12811-1:2003

Charge ponctuelle max. : 150 kg  
Charge répartie max. : 100 kg/m<sup>2</sup>

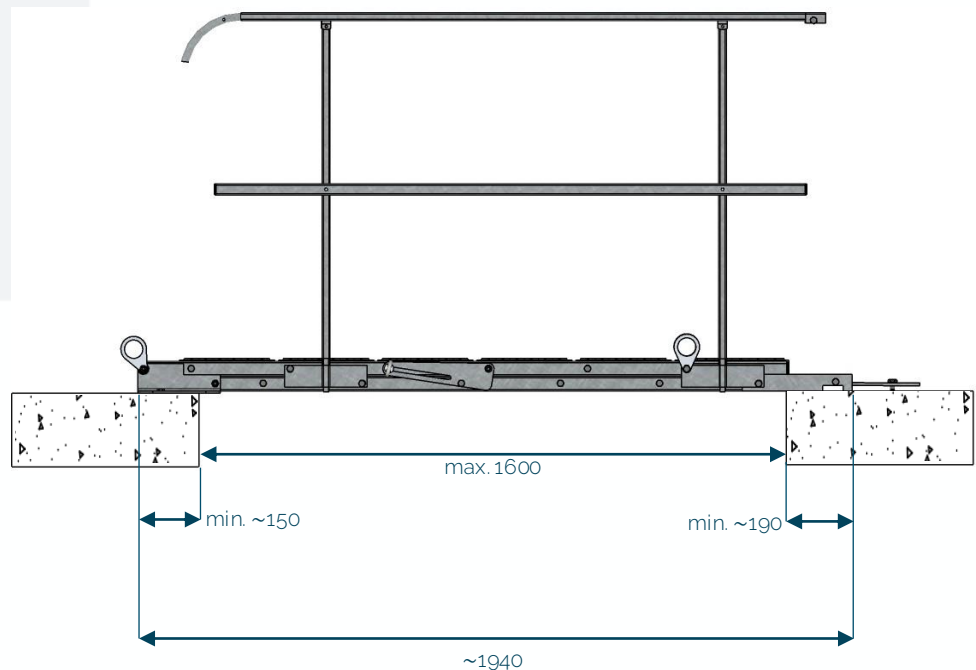
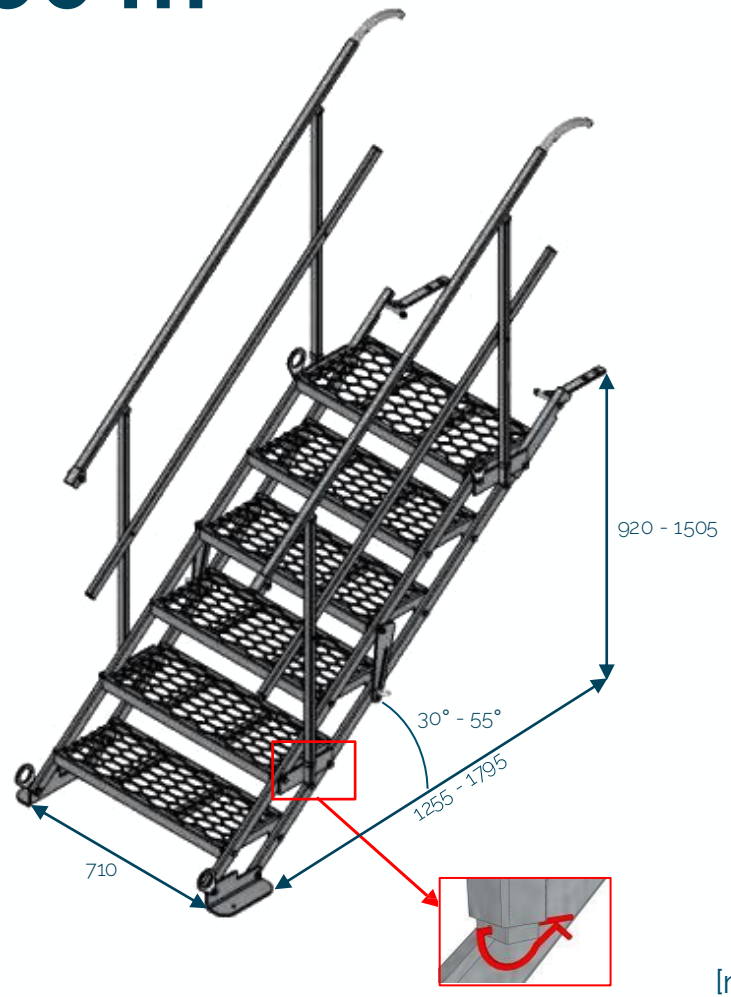
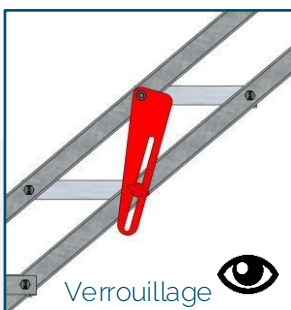
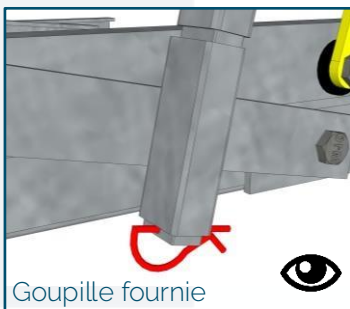
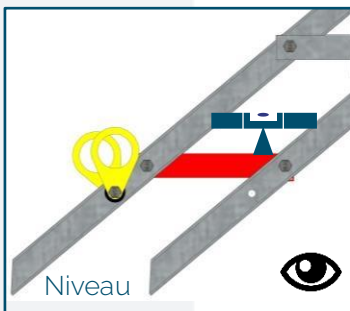

# Escalier 9 marches Passerelle 2,40 m

Code : N221-020

85 kg

EN 12811-1:2003

Charge ponctuelle max. : 150 kg  
Charge répartie max. : 100 kg/m<sup>2</sup>

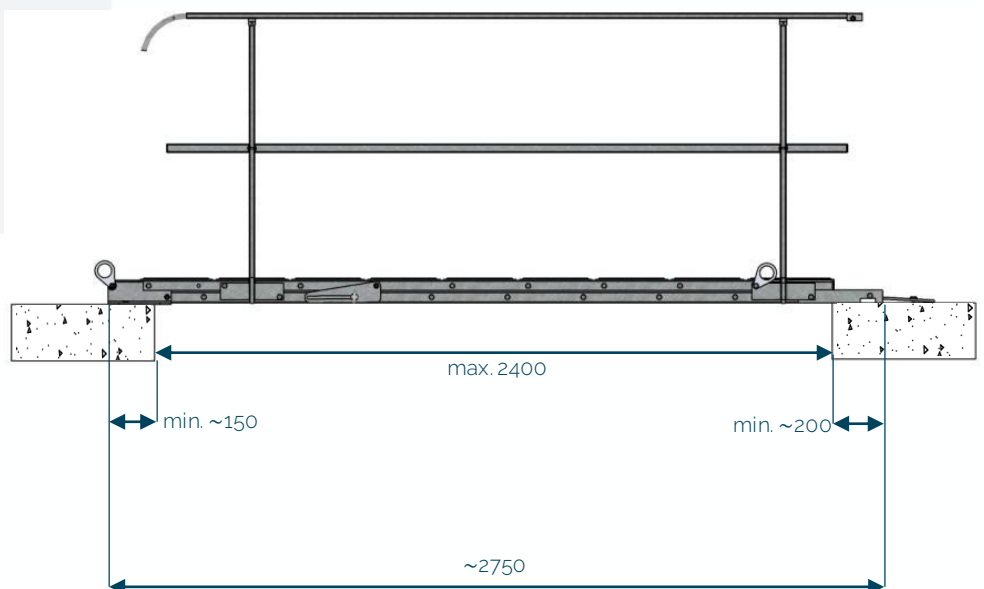
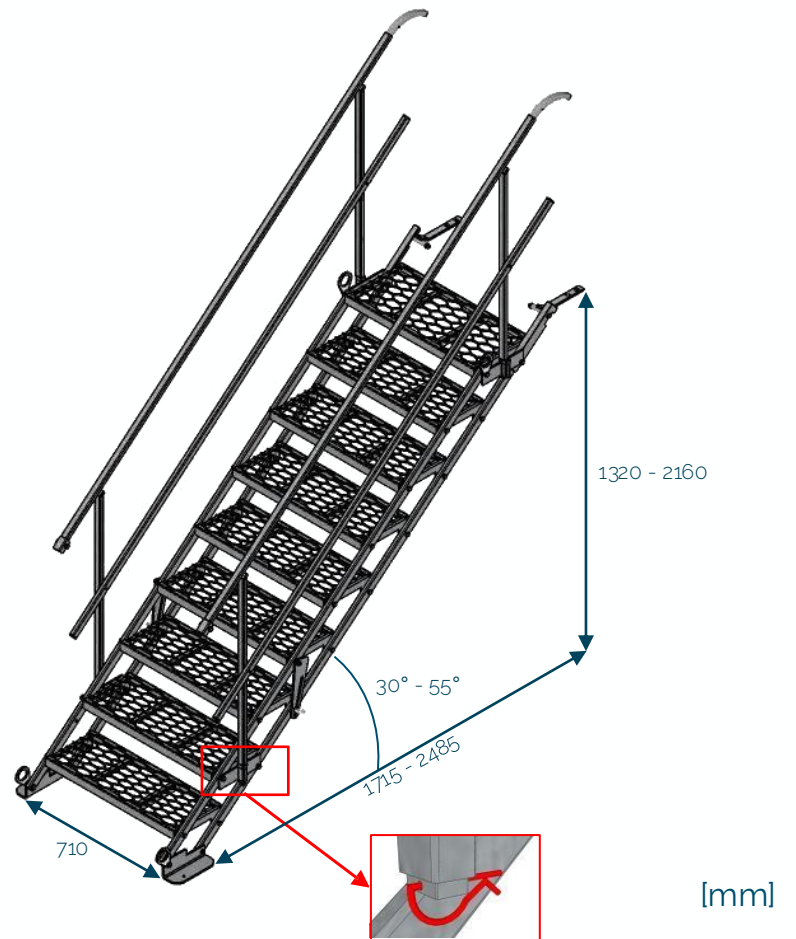
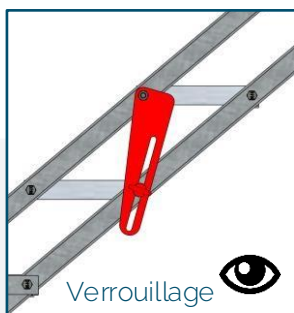
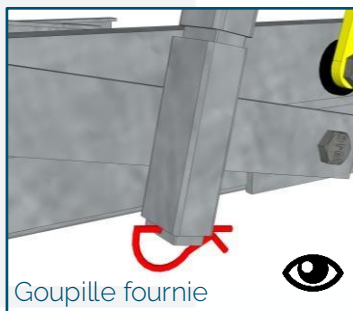
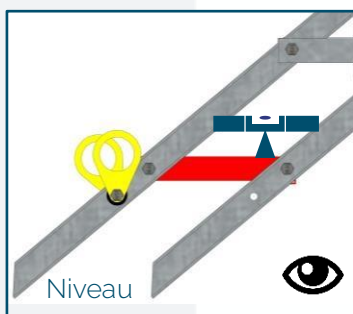

# Escalier 12 marches Passerelle 3,20 m

Code : N221-008

115 kg

EN 12811-1:2003

Charge ponctuelle max. : 150 kg  
Charge répartie max. : 100 kg/m<sup>2</sup>

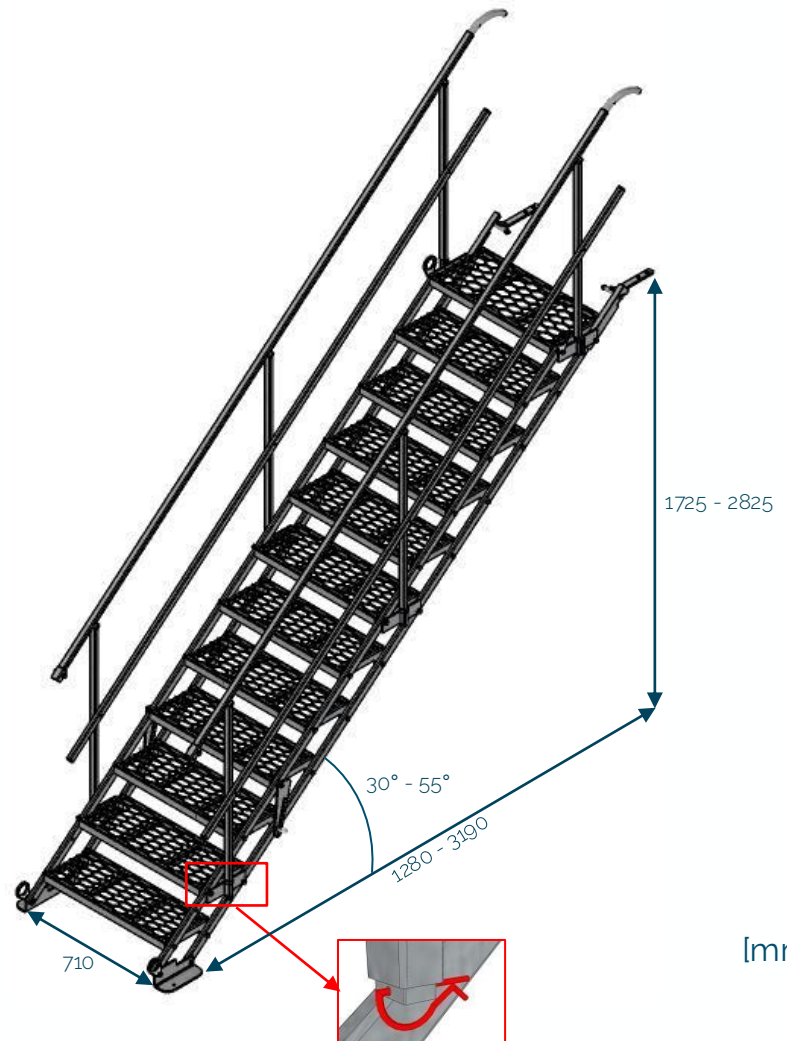
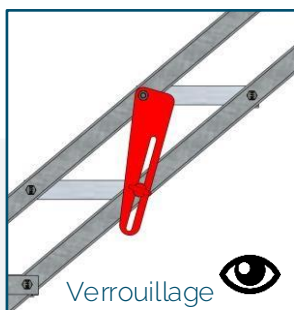
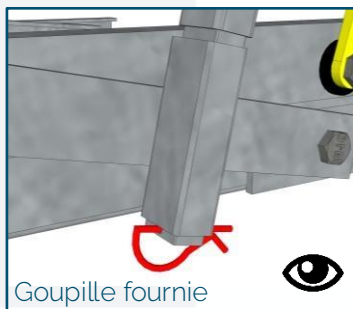
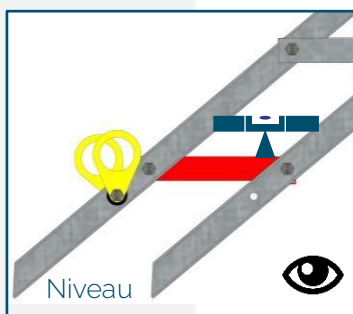

[mm]

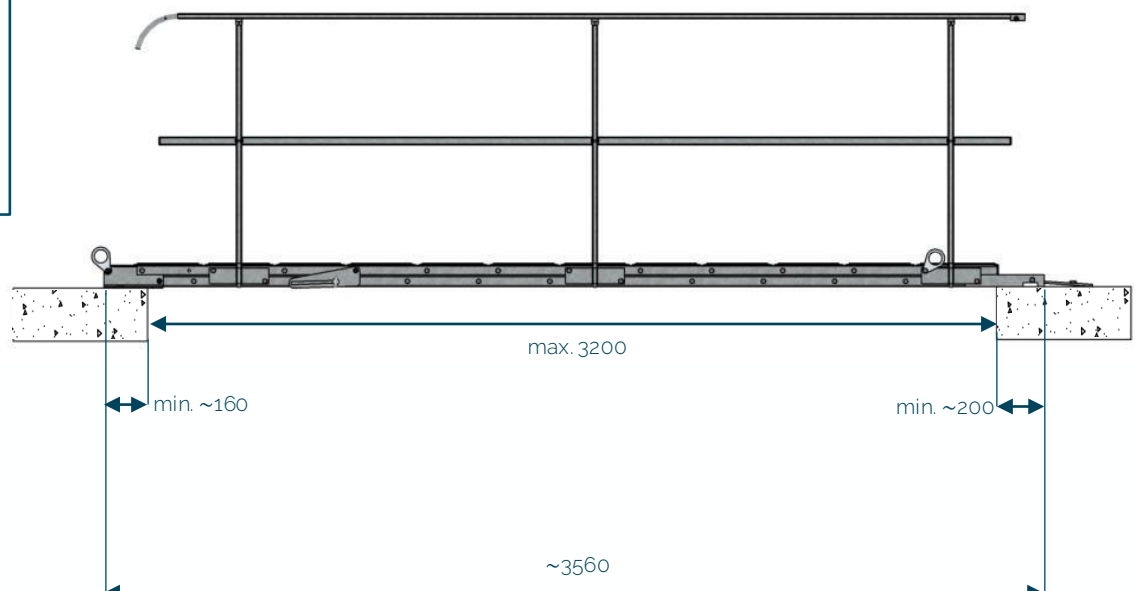

# Plage d'utilisation

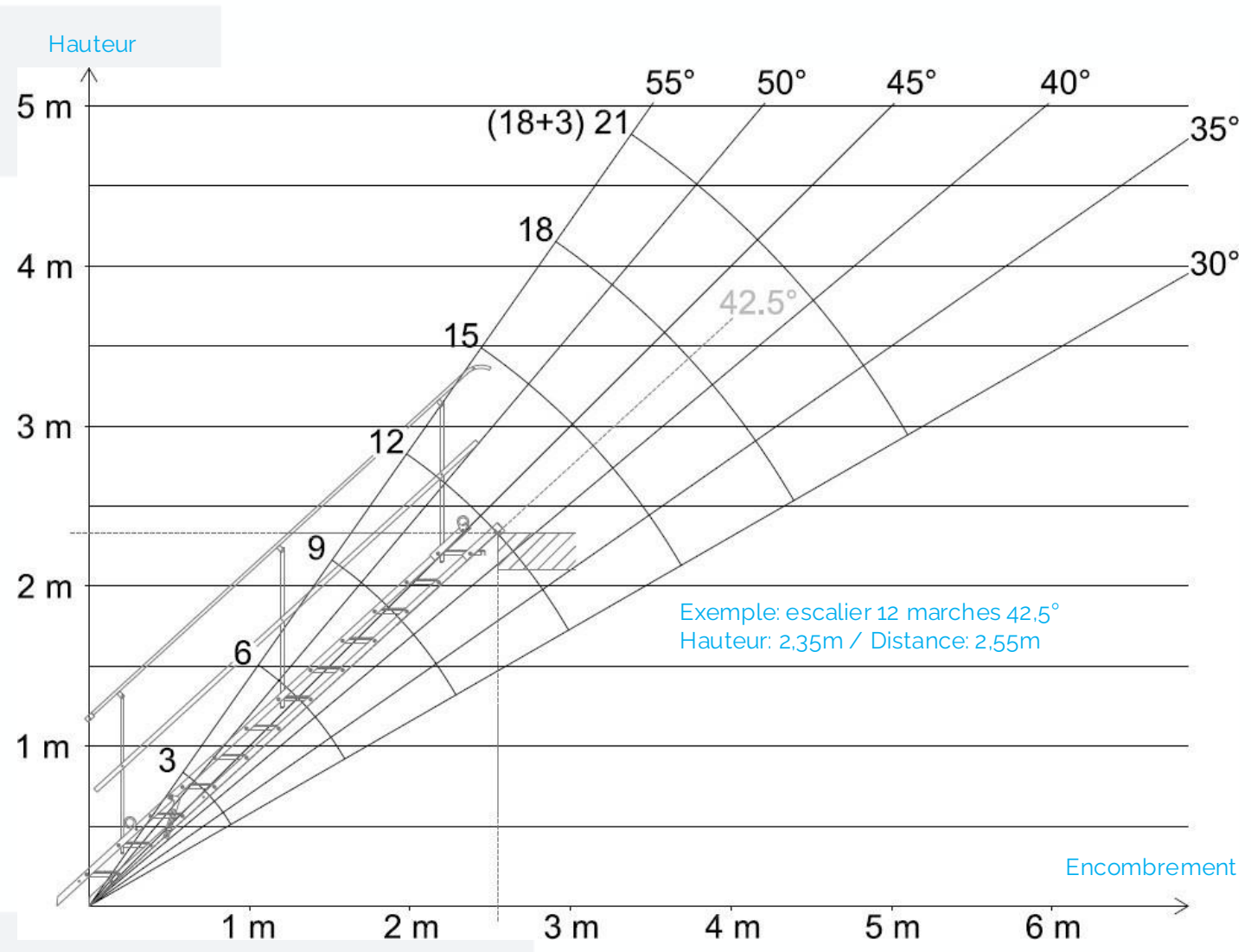

# Maintenance préventive

*Avant et après chaque utilisation / hebdomadaire / annuelle de :*

Système de verrouillage

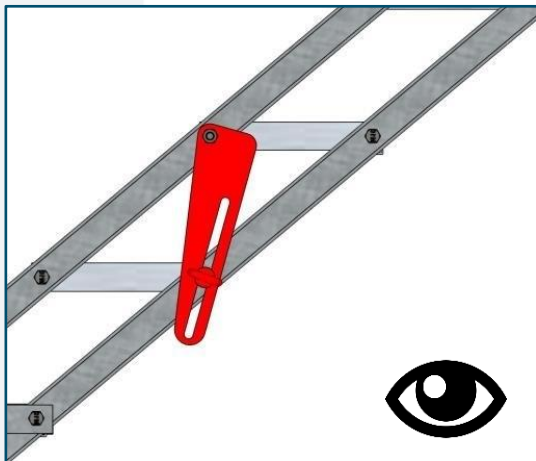

Anneaux de levage amovibles

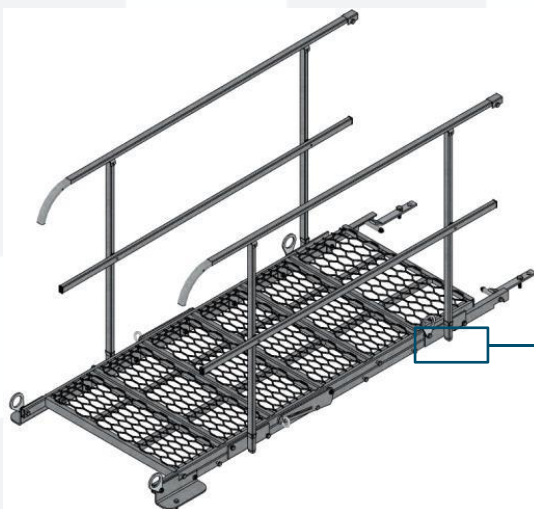
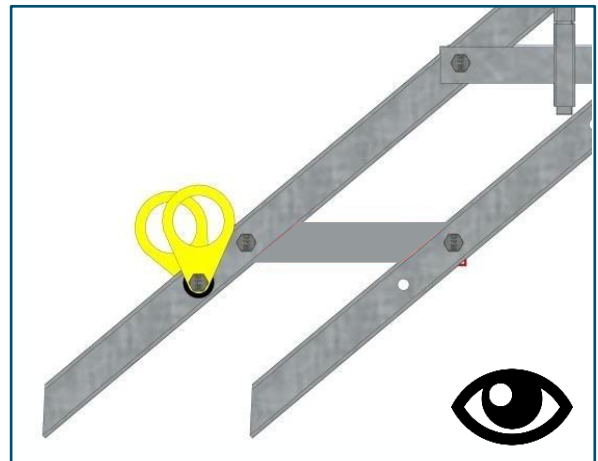

Goupille de verrouillage GC

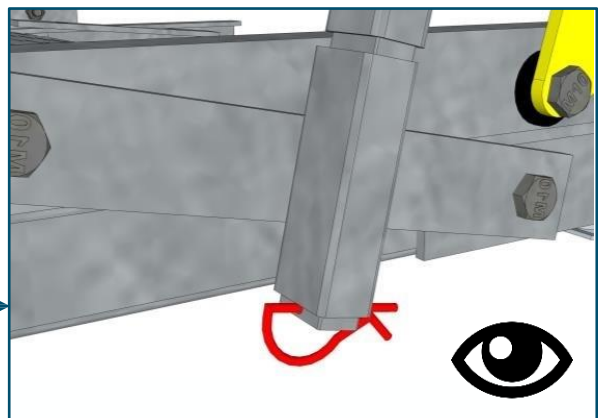

**Anneaux amovibles :** vérification avant et après chaque utilisation de la présence des **éléments de serrage** et vérification annuelle supplémentaire obligatoire

## HAKI FRANCE

Parc Technoland – Bâtiment C  
3 allée du Lazio  
69800 SAINT-PRIEST  
France

## DÉPÔT LOGISTIQUE

447 Chemin de la Roche  
38510 SERMERIEU - France  
Coordonnées Google:  
45.692147, 5.391563

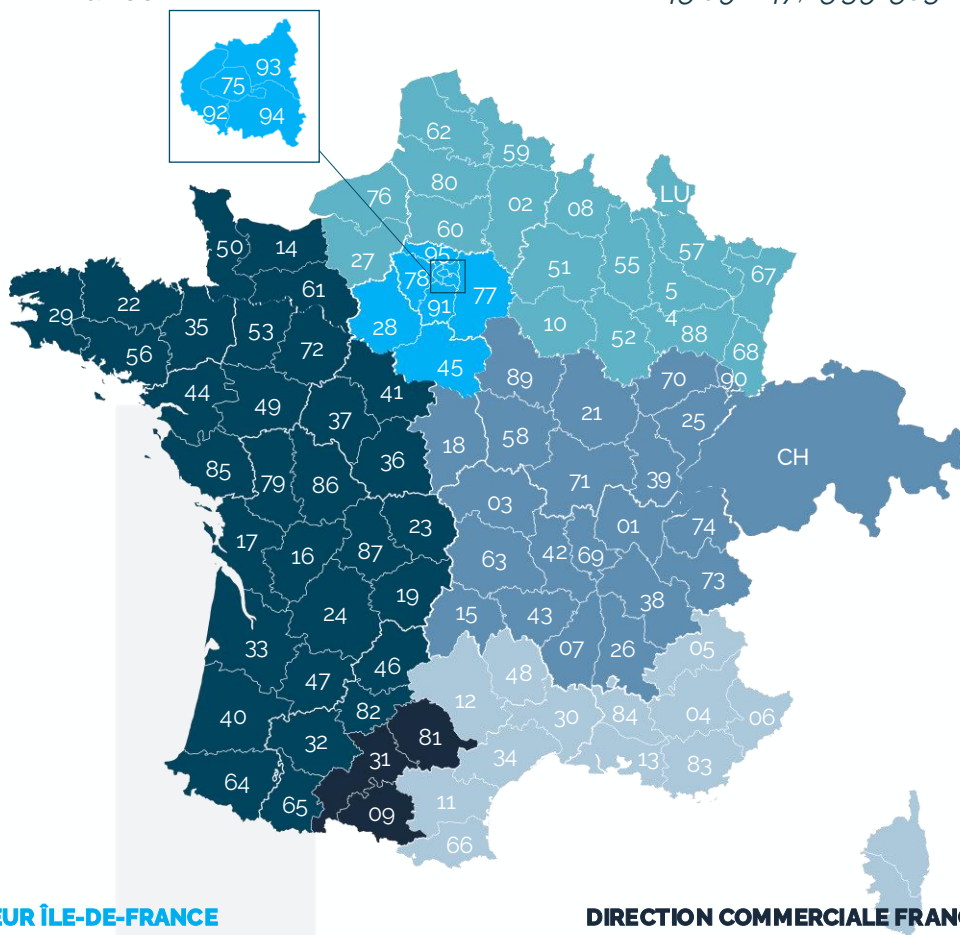

### SECTEUR ÎLE-DE-FRANCE

Jean-Christophe Davril  
[jean-christophe.davril@haki.com](mailto:jean-christophe.davril@haki.com)  
+33 7 86 33 28 12

### SECTEUR GRAND OUEST

Cyrille Derré  
[cyrille.derre@haki.com](mailto:cyrille.derre@haki.com)  
+33 6 32 58 34 84

### SECTEUR NORD – NORMANDIE – GRAND EST – LUXEMBOURG

Simon Flandrin  
[simon.flandrin@haki.com](mailto:simon.flandrin@haki.com)  
+33 6 71 79 24 75

### SECTEUR SUD - MONACO

Nicolas Meunier  
[nicolas.meunier@haki.com](mailto:nicolas.meunier@haki.com)  
+33 6 38 87 25 63

### COMMERCIALE SÉDENTAIRE FRANCE – RÉFÉRENTE TRAVAUX PUBLICS

Clara Riccialdelli  
[clara.riccialdelli@haki.com](mailto:clara.riccialdelli@haki.com)  
+33 6 85 38 94 27

### DIRECTION COMMERCIALE FRANCE

Adrien Durand-Raucher  
[adrien.durand-raucher@haki.com](mailto:adrien.durand-raucher@haki.com)  
+33 7 85 45 86 80

### DIRECTION COMMERCIALE SUISSE

#### SECTEUR RHÔNE-ALPES - CENTRE

Julien Cru  
[julien.cru@haki.com](mailto:julien.cru@haki.com)  
+33 6 33 59 73 49 / +41 79 510 18 69

### EXPORT & GRANDS PROJETS

Thierry Alonzi  
[thierry.alonzi@haki.com](mailto:thierry.alonzi@haki.com)  
+33 6 31 45 15 03

Auguste Martin  
[auguste.martin@haki.com](mailto:auguste.martin@haki.com)  
+33 6 74 96 92 07

### DIRECTION GÉNÉRALE

Thomas Garcia  
[thomas.garcia@haki.com](mailto:thomas.garcia@haki.com)  
+33 6 75 68 08 81